

CHAPTER 19

LIVE FIRE TACTICAL TRAINING AREA RANGE & CLOSE QUARTER BATTLE (RURAL) RANGE

INTRODUCTION

1901. **General.** Field Firing Areas now termed Live Fire Tactical Training Areas (LFTTA) provide very realistic battle conditions having no artificial lanes and few structures to limit the arcs of fire. The scale of use is from individual to brigade level exercises. The concepts in this Chapter refer also to Close Quarter Battle (Rural), CQB(R) ranges. LFTT is only to take place in accordance with Reference B (Pamphlet 21). On some ranges, urban training facilities are provided.

1902. **Aim.** This chapter covers the facilities that may be required on an LFTTA and in particular:

- | | | |
|----|---------------------------|-------------|
| a. | Introduction | 1901 - 1903 |
| b. | Danger areas | 1904 - 1906 |
| c. | Design | 1907 |
| d. | Construction | |
| | (1) General | 1910 |
| | (2) Targetry | 1911 - 1912 |
| | (3) Firing area | 1913 - 1914 |
| | (4) Firing positions | 1915 - 1918 |
| | (5) Supporting structures | 1919 |
| e. | Communications | 1920 - 1921 |
| f. | Maintenance | 1922 - 1924 |

1903. **Purpose.** The LFTTA provides natural ground conditions for training in Transition to and Live Fire Tactical Training (TLFTT & LFTT) of Reference C (Army Operational Shooting Policy).

DANGER AREAS

1904. **RDA.** Full advantage of the area can only be obtained by careful application of the appropriate WDA templates, and selection of movement boxes and target locations. Instructions for constructing RDA traces are given in Reference B (Pamphlet 21).

1905. **WDA Templates.** WDA templates for SA ammunition are illustrated in the Figures 19-2 and 19-3 to this Chapter. Where ricochet from ground strike may be expected use Figure 19-2. For HEF where no ground strike is expected use Figure 19-3. Other IWS may form part of a field firing exercise and their WDA need to be included into the RDA trace. These IWS WDA are to be found in the appropriate Chapter of this Volume.

1906. **Impact Areas.** Refer to Chapter 2.

DESIGN

1907. Design Criteria

- a. **Size.** The size of the area, the ground conditions and arcs of fire available will determine the size and scope of the field firing exercise which can take place. The WDA templates illustrated in this Chapter and the relevant Chapters of this Volume give the areas required for various circumstances. The exception will be where troops exercise overseas and the host nation WDA are greater than UK standard WDA. In this case the host nation WDA are to be used on the perimeter of the allocated training area.
- b. **Scope.** The LFTTA should provide scope for realistic firing training in all phases of war using as wide a variety of SA and IWS ammunition natures as possible.

1908. **Siting.** Any ground suitable to the purposes of the exercise may be used. Rocky ground should be avoided in the target areas as this will create backslash and ricochet dangers, and difficulty in excavating target pits. Where multiple CQB(R) trails are set out in difficult ground where there is no inter visibility, Planning Officers must ensure there is template separation for each engagement possibility.

1909. **Application of WDA Template 530 mils (30⁰) Ground Ricochet Angle.** The 530 mils (30⁰) ground ricochet angle is applied from the firing position on the basis that the ground in front of the firer is clear of hard surfaces within his CofF for at least 50 m (the backslash limit).

CONSTRUCTION

GENERAL

1910. As little construction as possible should be carried out on a LFTTA. The aim must be to maintain both flexibility and natural ground conditions. However, it may be necessary to construct or erect:

- a. Protection for target mechanisms
- b. Effects bunkers
- c. Arc and movement box markers
- d. Trenches and weapon pits
- e. Grenade posting and throwing facilities.
- f. Overhead or effects SA positions.
- g. Urban training façades.

TARGETRY

1911. **Targets.** A wide variety of improvised and issued targets may be employed on a LFTTA(see Chapter 29). The protection described below refers to temporary target positions only.

1912. **Target Protection.** Static target mechanisms should be installed in dug out pits or positioned behind protective raised banks or bunds. Moving target mechanisms and associated rails must be similarly protected over the

full length of the target run. Target mechanism protection against SA fire can be achieved by 500 mm of well compacted stone-free soil, 500 mm of sand filled sandbags or 200 mm (100 mm for 0.22 m rimfire and 9 mm ammunition) of softwood timber. If target mechanisms are to be left out in a permanent or semi-permanent position, bullet protection using wooden clad MS plates, proper drainage and some form of weather/security cover for the mechanism must be considered and where necessary provided.

FIRING AREA

1913. **Effects Bunkers.** Effects bunkers protect battle effects simulation teams from the ammunition for which the range is authorised. A bunker accommodates a minimum of two people sitting. The construction details of a typical bunker are shown in Figure 19-1. The bunker must be out of the direct Loff, and protected on three sides and overhead by an earth mound or dug into the face of rising ground. The minimum thickness of earth required is 1.5 m at the sides and rear, and 500 mm overhead. The mound is grassed to prevent erosion. Each bunker has a removable flag pole of sufficient height to ensure that when a 1.2 x 0.9 m red flag is flown, it can be seen from all points of the movement box. Alternatively, a pivot pole with a red disc or ball on the raised end (as for the MMTTR bunker in Chapter 20) is to be fitted across the front of the bunker. A battery operated red light is required for night firing.

1914. **Arc Markers.** Arc markers should only be erected when their use is essential to safety; such as when natural or constructed features cannot be clearly identified as marking the extremities of arc, or when the exercise is designed using points A-F as described in reference B (Pamphlet 21). Arc markers should be painted in distinctive colours and set so that they are clearly visible.

FIRING POSITIONS

1915. **Fire Trenches.** The construction of pre-dug positions should generally be avoided. It may however be necessary to construct a permanent facility such as a defensive position and care needs to be taken to reduce any resultant hazard to the general public. Revetting may be either timber or pre-formed concrete box sections with the top 225 mm of timber. Drainage will be required in permanent trenches. For details of temporary firing positions see relevant chapters.

1916. **Movement Boxes.** As with arc markers, the marking of a movement box is to be avoided and only established where the limitations of the training area make it unavoidable. Where a requirement exists, movement boxes must be clearly marked out on the ground to avoid confusion. Timber marker posts painted in distinctive colours may mark the boundaries, and changes in arcs of fire or bearings (See Reference B (Pamphlet 21)).

1917. **Grenade Throwing.** Details of trenches and bunkers for tactical grenade throwing are given in Chapter 22.

1918. **Effects Guns.** The rules to be applied for using effects guns are contained in Reference B (Pamphlet 21). Overhead fire towers may be provided with predetermined arcs of fire that include cleared areas out at 500 m to enable correct setting of sights as set out in Reference B.

SUPPORTING STRUCTURES

1919. Range structures constructed on a PTR fall into three categories:

- a. Permanent structures constructed by the RAU in accordance with the criteria in this JSP. Details for structures in support of urban training are covered in Chapter 6. Details for HE grenade throwing is provided in Chapter 22. All permanent structures are to be added to the estate asset register to ensure funding for maintenance is provided and annual works inspections on the structures are carried out.
- b. Temporary structures provided by the RAU but erected by exercising troops. These are normally shoot through training aids in support of current operations. Such structures are to be intrinsically safe to ensure close engagement is possible without risk of backsplash or unexpected ricochet.
- c. Permanent and temporary HE grenade throwing structures. The protection requirements are set out in this JSP for permanent structures and in Reference B (Pam 21) for temporary structures. .

COMMUNICATIONS

1920. **External.** A means of summoning the emergency services, ideally a land laid telephone, is to be available.

1921. **Internal.** Radio is the preferred method of communication, adding realism to the exercise. A fail-safe back up system is however essential. A direct and reliable link to range control should be available where possible. Effects bunkers, overhead fire, effects weapons and battle simulation control may require an installed telephone link with buried and protected lines.

MAINTENANCE

1922. **Responsibilities.** Sufficient stores will be required as a LFTTA will normally require a large quantity of target mechanisms, targetry, defence stores and grounds maintenance equipment. A workshop should also be available to service and repair targets and target mechanisms, and for battery charging. Stores and workshops should be conveniently sited and connected by a metalled road. Maintenance of a LFTTA is the responsibility of the RAU. Responsibilities may be divided as follows:

- a. **Range Warden.** See Reference A1.
- b. **Property Management**
 - (1) Building and structure maintenance, including overhead fire towers, services, earthworks and, if applicable, Armoured Fighting Vehicle (AFV) route repairs.
 - (2) Moving targets or repairing the ground around targets to prevent firers recognising the area before targets appear.
 - (3) Grass, shrubs and trees are essential to the natural cover and will need cutting, pruning and a planting or re-seeding programme.
 - (4) For fencing and signing.

- c. **Equipment Management.** Repairing and servicing equipment installed by single Service contract.

1923. **Backsplash Hazards.** To reduce the hazard of backsplash, particular care is required to monitor shot damage to target pits to ensure that soil erosion does not expose rocky areas.

1924. **Frequency.** Proper maintenance depends on good liaison between the Range Warden and the RAU, and on properly scheduled maintenance periods. A heavily used LFTTA may require two to four days' maintenance by the Range Warden each month. Two closed periods may be needed each year for planting and earthworks to preserve the natural environment.

Reference W

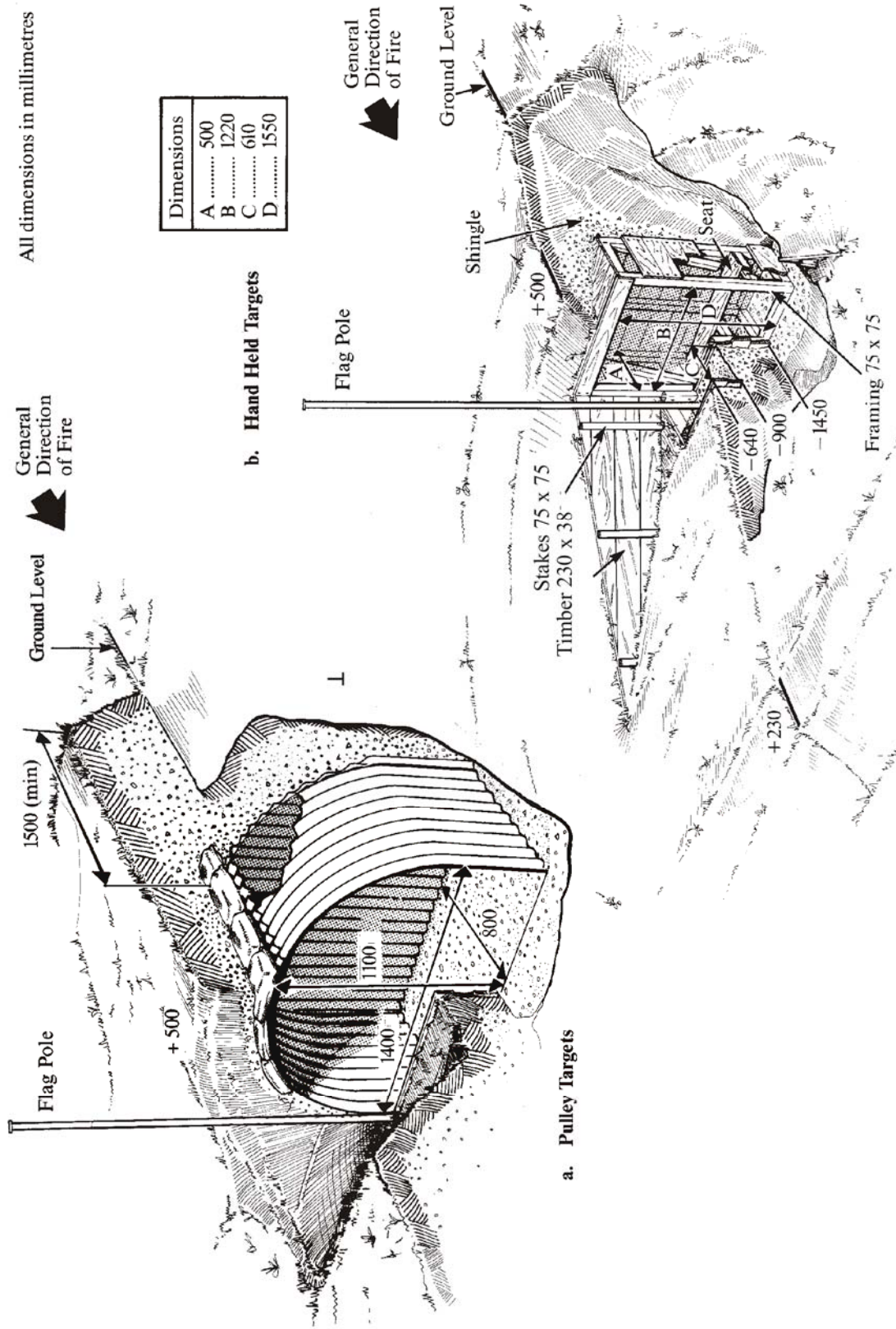
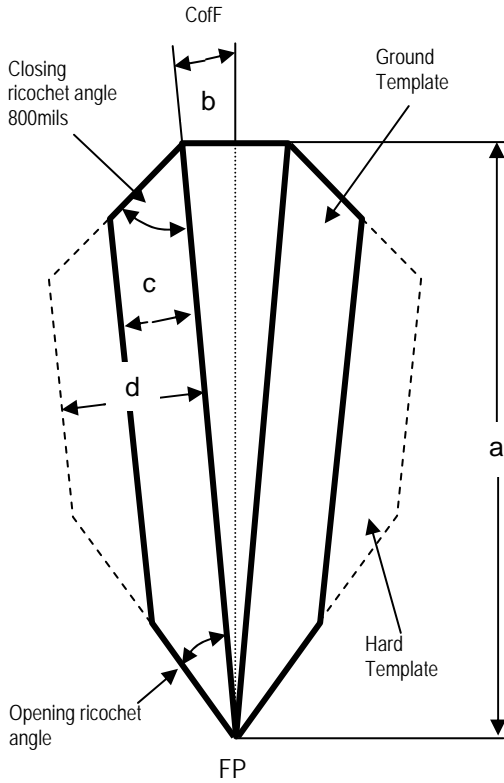

Figure 19 - 1. Effects Bunker

Not to scale Not to be copied

Reference: DLRSC July 2011



Ser	Ammunition Used	Measurements Applied						
		mils	(m)	mils	(m)	(m)		
		Opening angle	a	b	c	d		
1	5.56 & 7.62mm CoF captured by the ground. No QE restriction.	530	2900	note 3	400	800		
2	5.56 & 7.62mm CoF not captured by the ground. QE < 150mils		2900					
3	5.56 & 7.62mm CoF not captured by the ground. QE > 150 but < 1250 .		4000					
4	0.50inch. CoF captured by the ground, no QE restriction.		5200					
5	0.50inch. CoF not captured by the ground, QE < 150mils.		5200					
6	0.50inch. CoF not captured by the ground, QE > 150 but < 1250.	6400	270	60/90	650	1300		
7	9mm carbine QE < 220	1500					200	400
8	0.22inch MV < 330m/s QE <150mils	1200					150	300
9	0.22inch MV > 330m/s QE <150mils	1300					175	350
10	0.22inch QE > 150mils	1550	175	350				
11	5.56 & 7.62mm Moving Vehicle	530	4000	120/150	400	800		
12	0.5inch Moving Vehicle	530	6400	150	650	1300		
13	9mm Pistol QE < 220mils	270	1500	250	200	400		
14	9mm Pistol QE >220mils	270	1825	250	200	400		
15	.338" (8.6mm)QE <150mils ball	530	3700	note 8	450	900		
16	.338" (8.6mm) QE >150mils	530	5500	note 8	450	900		
17	4.6mm (MDP PDW)	270	1400	note 9	450	900		
18	UGL HEDP	530	500	100	75	n/a		
19	GMG Prac / HEDP static/static		2400	40	300	600		
20	GMG Prac/HEDP static / moving		2400	90	300	600		
21	GMG Prac/HEDP moving		2400	Note 3				
22	Combat Shotgun slug	800	680	80	360	n/a		
23	Combat Shotgun buck shot	n/a	580	80+200	n/a	n/a		

WDA Template Dimensions

Notes;

1. The application of the WDA template is given in Reference B (Pamphlet 21).
2. The ground template is only to be used when penetrable targets are engaged on ground free from any hard ricochet or backsplash inducing material.
3. Column b:
Serials 1-10 static to static single shot and burst fire = 60mils; moving targets = 90mils.
Serials 11-12 & 21 moving vehicles on prepared flat ground = 120mils; on rough ground = 150mils.
For other Coff angles see Chapter 2 Table 3.
4. All ADH information is provided in Chapter 2 Table 1.
5. This table refers to Ball, tracer or in serials >150mils, AP ammunition.
6. UGL HEDP Ser.18 has RBSD of 315m and NBSD of 450m. Minimum engagement distance is 150m.
7. GMG HEDP Ser.20 has RBSD of 220m and NBSD of 310m. Minimum engagement distance is 220m.
8. See Fig. 19-4.
9. As carbine – 60 mils. As pistol (butt folded) – 250 mils.

Figure 19-2. WDA Template SA

**Not to Scale
Not to be copied**

Reference: D/DEO(CS)/70/49/5/2 Mar 98

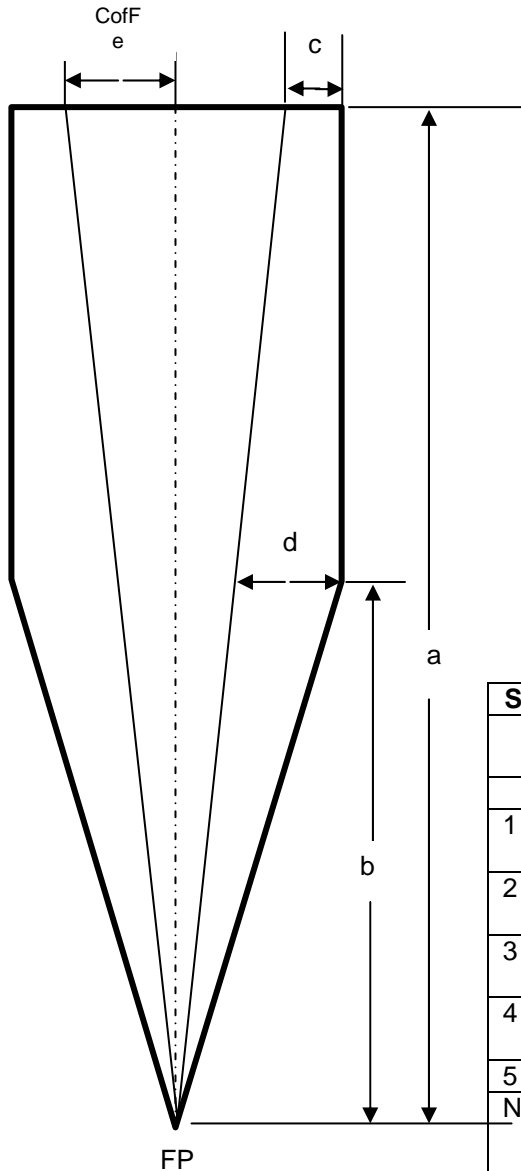

Ser	Ammunition	Measurements to be Applied				
		(m)	(m)	(m)	(m)	(mils)
		(a)	(b)	(c)	(d)	(e)
1	5.56 & 7.62mm	4000	2100	200	325	150
2	12.7mm (0.5")	6400	4000	250	350	150
3	.22", < 330m/s	1450	800	100	175	150
4	.22", > 330m/s	1550	800	100	175	150
5	9mm ball	1825	1000	150	200	40

Note:

1. Dimension 'd' represents an allowance for wind.
2. For ADH refer to Chapter 2 Table 1.
3. Ball, tracer or AP.
4. 9mm (less moving vehicle) Vertex Ht.1225m
5. Details for 4.6mm ammunition awaited.

**Figure 19-3. HEF WDA Template SA Ammunition
QE > 150 < 1250mils.**

Not to scale Not to be copied

Reference: DCC/20/12/19 dated 2 Jul 04

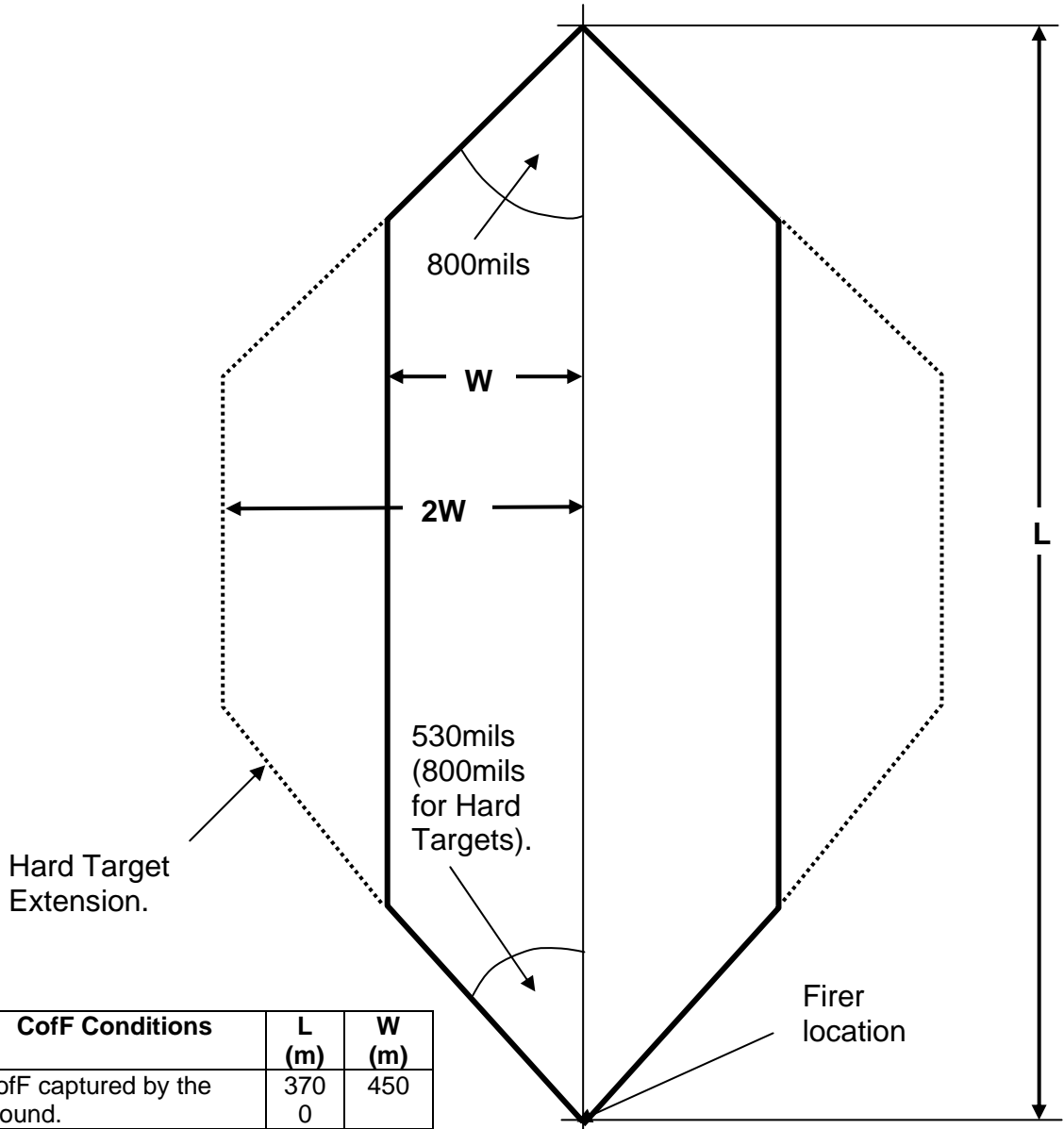

Se r	CofF Conditions	L (m)	W (m)
1	CofF captured by the ground.	370 0	450
2	CofF not captured by the ground. QE<150mils.	370 0	450
3	CofF not captured by the ground. QE>150mils.	550 0	450

Notes;

1. The CofF is omitted from the template as it has been included in the overall calculation.
2. This template is for 8.6mm ball ammunition only.
3. ADH – 3000ft.

Figure 19-4. 8.6mm Long Range Rifle FFA Template

Not to scale Not to
be copied

Reference: D/LAND/TS/1/5/1 dated 15 Mar 04

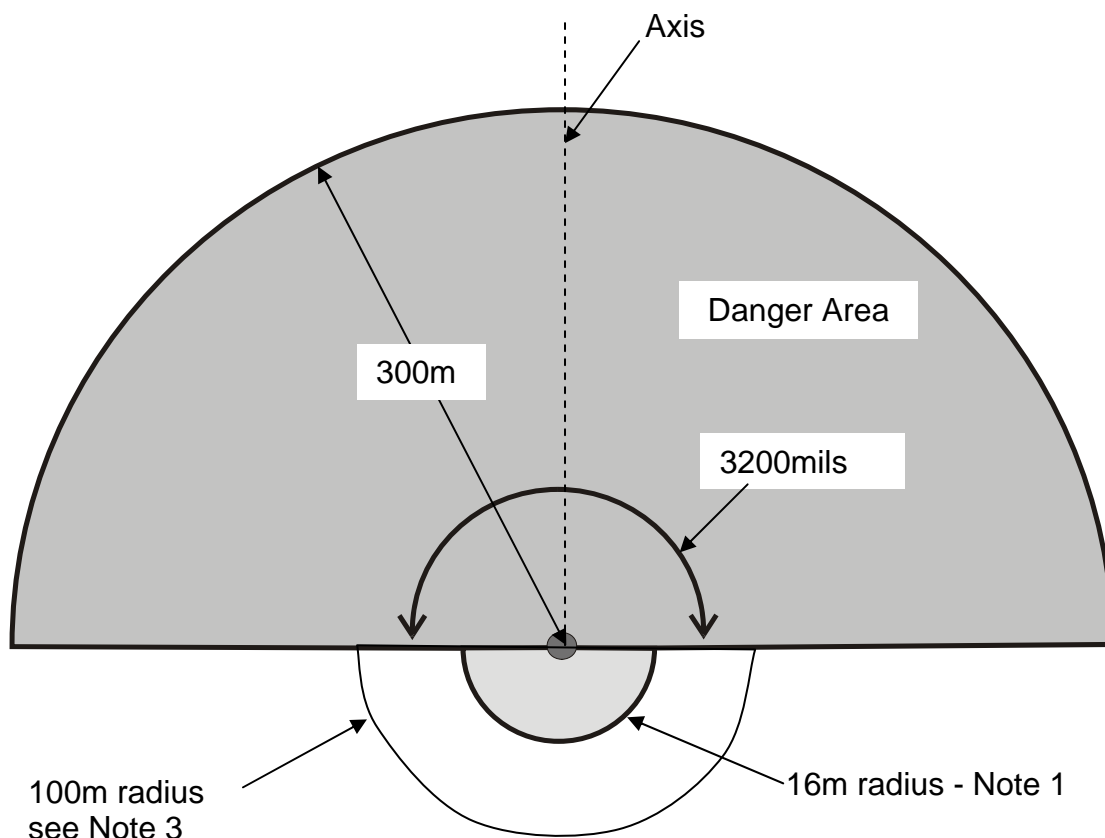

Figure 19-5 Weapon Danger Area (WDA) for M18A1 (Claymore)

Notes;

1. All personnel are to be excluded from the 16m area once the device is armed.
2. No personnel are to be forward of a line perpendicular to the axis of the device.
3. All personnel closer than 100m to the back of the device are to wear PPE and be behind cover.