

CHAPTER 8

THE 25 METRE BARRACK RANGE

INTRODUCTION

0801. **General.** The 25 metre Barrack Range is the current MOD standard 25m NDA range design. The range, which has a flat range floor, should not be confused with the 1908 designed 30 yard Barrack Range which has been metricated. The 1908 design has limitations which do not apply to this range. This range may be distinguished by it's cantilevered back wall.



0802. **Aim.** This chapter sets out the design criteria and construction requirements of this barrack range. In particular it covers:

- a. Introduction 0801 - 0804
- b. Design 0805 - 0809
- c. Construction
 - (1) General 0810 - 0811
 - (2) Target area 0812 - 0816
 - (3) Range floor 0817 - 0819
 - (4) Firing points 0820 - 0823
 - (5) Lighting 0824
- d. Communications 0825
- e. Maintenance 0826 - 0830
- f. Compliance Checks 0831

0803. **Description.** The standard range has six lanes on a flat range floor with a constructed firing point at 25 m and further firing positions at 20, 15 and 10 m. Where required it is possible to provide more than 6 lanes on a range although this will increase cost due to the greater span of the front wall over the bullet trap.

0804. **Purpose.** The barrack range provides a local facility for limited firing practices up to 25 m. The range is suitable for carrying out the authorised pistol practices, introduction to shooting, remedial training, preliminary

grouping and zeroing, and training sub-unit shooting coaches. Harmonisation Screens cannot be used on this range.

DESIGN

0805. **General.** The range is intended for use in or close to barracks or garrison areas. An increased safety factor has been achieved by moving the top of the stop butt wall forward to over the targets, which increases the angle from the firing points to the top of the wall, and by providing 11 m return wing walls either side of the bullet catcher. Consideration should be given to providing access to the stop butt for maintenance purposes (see para.0823). The range design is based on correctly aimed shots going into the bullet catcher, and also on capturing all shots fired with acceptable and some of the unacceptable aim deviations. The range layouts are shown in outline at Figures 8-1 and 8-2.

0806. **Siting.** The range requires a flat and level site on firm, well drained land. It should be orientated so that firing is in a northerly direction to avoid direct sunlight affecting firers' vision. Although the range has no DA, consideration should be given to activities and to the population density in the area around the site, particularly down-range and on the flanks.

0807. **SA Limitations.** Limitations on the maximum number of SA, ammunition and rates of fire that can be used on this range are given in Reference B (Pamphlet 21). These limitations give either an increased safety factor under difficult conditions or acknowledge that the design only caters for some practices, and for stable aimed firing.

0808. **Shot Guns.** The range design is suitable for shot guns firing solid slug or buck shot. Where ranges have significant solid slug practices deleading frequency may need to be increased to avoid the build up of lead at the MPI.

0809. **Noise.** Siting a barrack range as far as possible from centres of population is the best way of avoiding noise nuisance. No barrack range should be sited closer than 50 m to occupied buildings unless special precautions have been taken to insulate the building against noise. A barrack range firing high velocity weapons should not be within 1 km of sensitive buildings such as hospitals.

CONSTRUCTION

GENERAL

0810. **No Danger Area Range.** A NDA range is constructed so that all correctly aimed shot will be captured within the range and that it provides a safe environment for its users. The scale of the structures required represent a higher cost than that of a larger open range with a DA.

0811. **Dimensions.** A standard 6 lane range is approximately 32 m wide and 45 m long. Ancillary building and earth bunds may increase the plan area required.

TARGET AREA

0812. **Stop Butt Wall.** The wall is normally constructed in reinforced concrete, cast in situ. Concrete on the front canopy wall which might be struck must be clad with 50 mm thick timber on 50 mm timber battens (for fixing refer

to Chapter 2). The battens are fixed vertically to allow debris to drop. The inside walls of the bullet catcher chamber are left unclad to allow inspection for strike damage. For repairs to the stop butt wall see Chapter 2. Bullet strikes on the stop butt wall above or beside the bullet catcher are to be recorded in the Range Log (MOD Form 906). If such incidents occur frequently, the range configuration may need to be checked by TAS(RE). To ease inspection, the wall should be painted with an external sand or white paint and shot marks made good.

0813. Bullet Catcher. A sand or granulated rubber bullet catcher is contained in a concrete chamber set back into the stop butt wall. The toe of the bank falls just beyond the wall. In this design, the timber anti-splash cladding of the stop butt wall is extended 1 m below the top opening of the bullet catcher to prevent backsplash (for fixing refer to Chapter 2). The back and side walls of the bullet catcher chamber are not lined with timber to enable inspection and repair of shot damage to be carried out. It is essential that the height of the bank and the level of timber below the bullet catcher chamber opening are constructed as shown at Figure 8-3. This will ensure that the top of the bank is shielded by the anti-splash timber. A line painted on the back and side walls of the chamber indicate the level of the sand with a 1000 mm deep plateau on the top and a 34⁰ (600 mils) slope to the face of the bank. Details of the sand or granulate are given in Chapter 2.

0814. Target Centre Position. The target centre height of 1000 mm (C) above ground level at the target line is a cardinal factor in the range design and must be maintained for all targets (see Figure 8-4). A white line is painted on the bullet catcher wing walls to indicate target centres and a line to indicate flank limits beyond which targets are not to be placed.

0815. Target Spacing. The number of targets per lane may be varied to meet training objectives but spacing should be:

- a. 2.00 m minimum from the edge of the bullet catcher to the flank target centres.
- b. 1.00 m minimum between target centres lane to lane.
- c. Targets in each lane should be at least 375mm apart.

Note: Other layouts may be adopted for pistol practices but subparagraph a. above remains the minimum.

0816. Target Mechanisms and Screens. A hand operated, turning target mechanism presents two figure targets in each lane. On new ranges or when major refurbishment is undertaken, the range can be improved by installing electrically operated turning targets. These are controlled from the firing point and may be powered by battery or mains electricity through a transformer. Zeroing screens and Target screens may be used on this range but Harmonisation screens are not to be used due to the maximum permitted target height.

RANGE FLOOR

0817. Configuration. The range floor is flat and level. It must be surfaced with a minimum of 150 mm of soil free from large stones (>30 mm in any dimension) and it has to be firm, free draining and should be bound with grass

or similar ground cover which is kept cut short. Any paths provided are to be constructed of ricochet free material.

0818. Range Side Walls. The design provides for the addition of concrete side walls to the range. These are not essential beyond 11m but may be built if it is considered expedient to raise the confidence of people near the range.

0819. Fences and Signs. All access to the range when in use must be controlled. The standard range is enclosed with access for users at the rear of the range and vehicular access provided for range maintenance. Ranges that are in open access areas, particularly those where woods or shrubs come close to the stop butt or side of the range should be fenced and signed to ensure access during firing is controlled. The same measures will be necessary where ranges with sloping earth bunds protect the sides of the range. Local risk assessments will identify areas where access will need to be controlled. Where fences are deemed to be necessary prohibition signs will also be required. A flag pole for a red range in use flag is provided where it can best be seen. If night firing is to be conducted, a red light is fitted to the flag pole. If the flag pole is on the stop butt wall, it must be made of non-ricochet inducing material.

FIRING POINTS

0820. 25 m Firing Point. The 25 m firing point is raised by 450 mm to create a near-level LofS from the prone position. All firing postures may be adopted. The surface may be of any low maintenance material fit for purpose.

0821. Other Firing Positions. The 10, 15 and 20 m firing points are for weapons fired from the standing or kneeling positions only. These firing points are not normally specially surfaced.

0822. Distance and Lane Markers. Timber markers should be suitably positioned to show distances and lane numbers on firing points.

0823. Access to Bullet Catcher. To ease maintenance, access to the bullet catcher through the side wall may be required. Should this option be incorporated, access doors will need to meet the centre fire rifle criteria for resistance to penetration in Chapter 2. Enhancement to the ground in front of the target will be necessary if vehicles are intended to use this access. Plastic grid sections are suitable "soft" track solutions.

LIGHTING

0824. The range may be provided with lighting for night practices but it is not designed for low light or LNV shooting. Where required the range is to be suitably illuminated to permit adequate visibility.

COMMUNICATIONS

0825. A means of summoning the emergency services, ideally a land laid telephone, is to be available.

MAINTENANCE

0826. Responsibilities. A high standard of maintenance is essential to the safety of a NDA range. Responsibilities may be divided as follows:

- a. **Range Warden.** See Reference A1.

b. **Property Management.** General inspection with particular emphasis on:

- (1) Cladded structures.
- (2) Fire trenches.
- (3) Fences and sign posts (see Chapter 2).

c. **Equipment Management.** Repairing and servicing equipment installed by single Service contract.

0827. **Frequency.** Proper maintenance is dependent upon good liaison between the Range Warden and the RAU, and on properly scheduled maintenance periods. A heavily used range may need one day's maintenance each week plus one or two days' maintenance by the Range Warden each month. Two closed periods of a week or so may be needed each year for building and earthworks repair; this work should be combined with the contract repair of equipment.

0828. **Bullet Catcher.** The requirements for maintaining the bullet catcher and de-leading are given in Chapter 2.

0829. **Stop Butt Wall.** Repairs should be undertaken when bullet strike erodes more than 10% into the back wall. Repair should be undertaken with epoxy fillers on concrete or with materials of similar strength to the eroded material where other materials are used.

0830. **Inspections.** Reference A1 (Volume I) defines the inspections to be carried out. On this range particular care has to be paid to the high walls and vertical canopy.

COMPLIANCE CHECKS.

0831. The compliance checks to be carried out are detailed below:

- a. Authorised weapons, ammunition and practices.
- b. Constructed in accordance with the ballistic elements on Type Drawing No 55702/3.
- c. Where pre cast – provision is be made to avoid straight joints in ballistic elements.
- d. If not constructed to the current Standard Barrack Range, then in accordance with compliance checklist for Open Non Standard NDA Range

All Dimensions in Metres

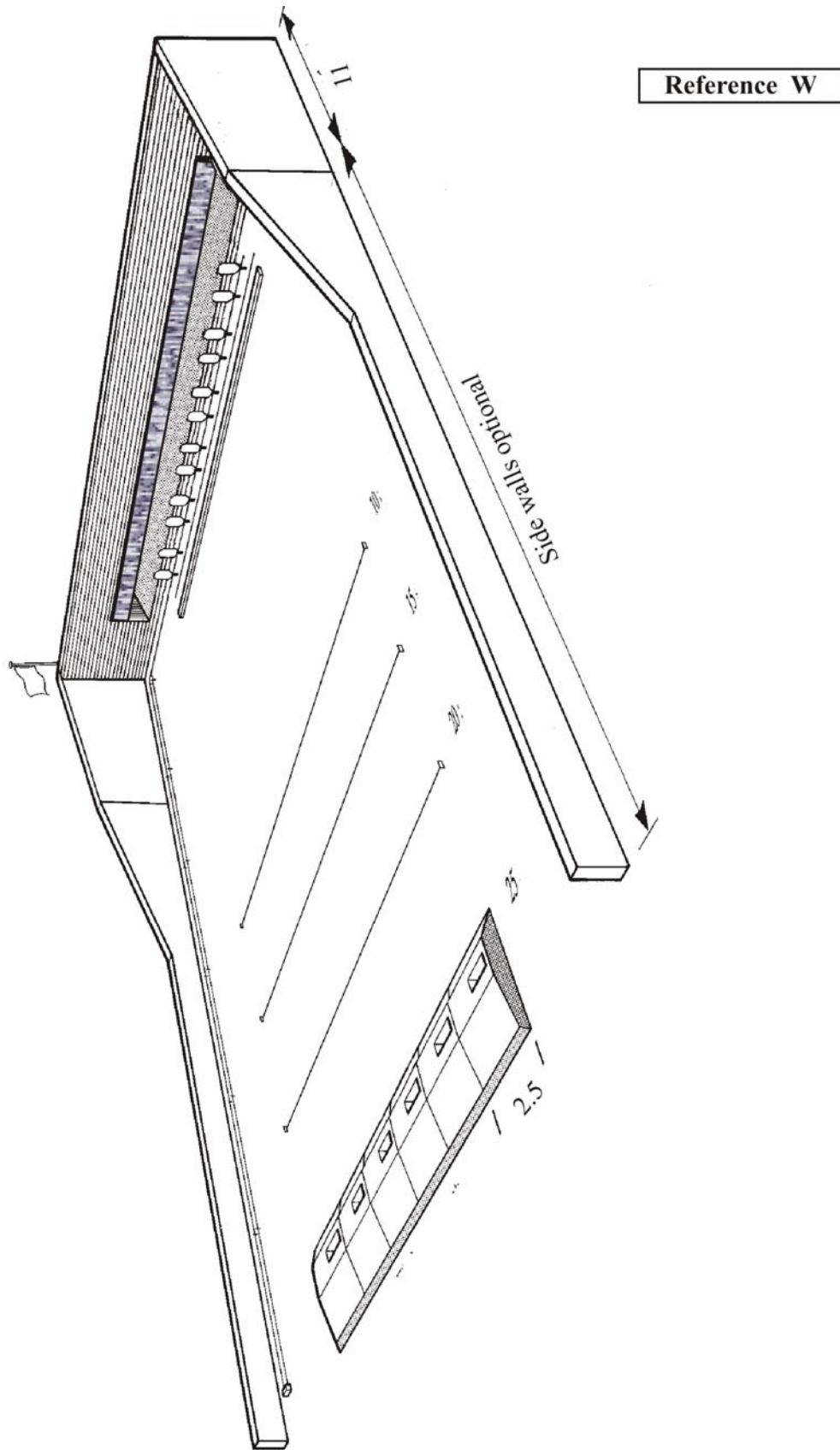

Figure 8 - 1. Typical Layout 25 Metre Barrack Range

Reference Type Drawing 55702

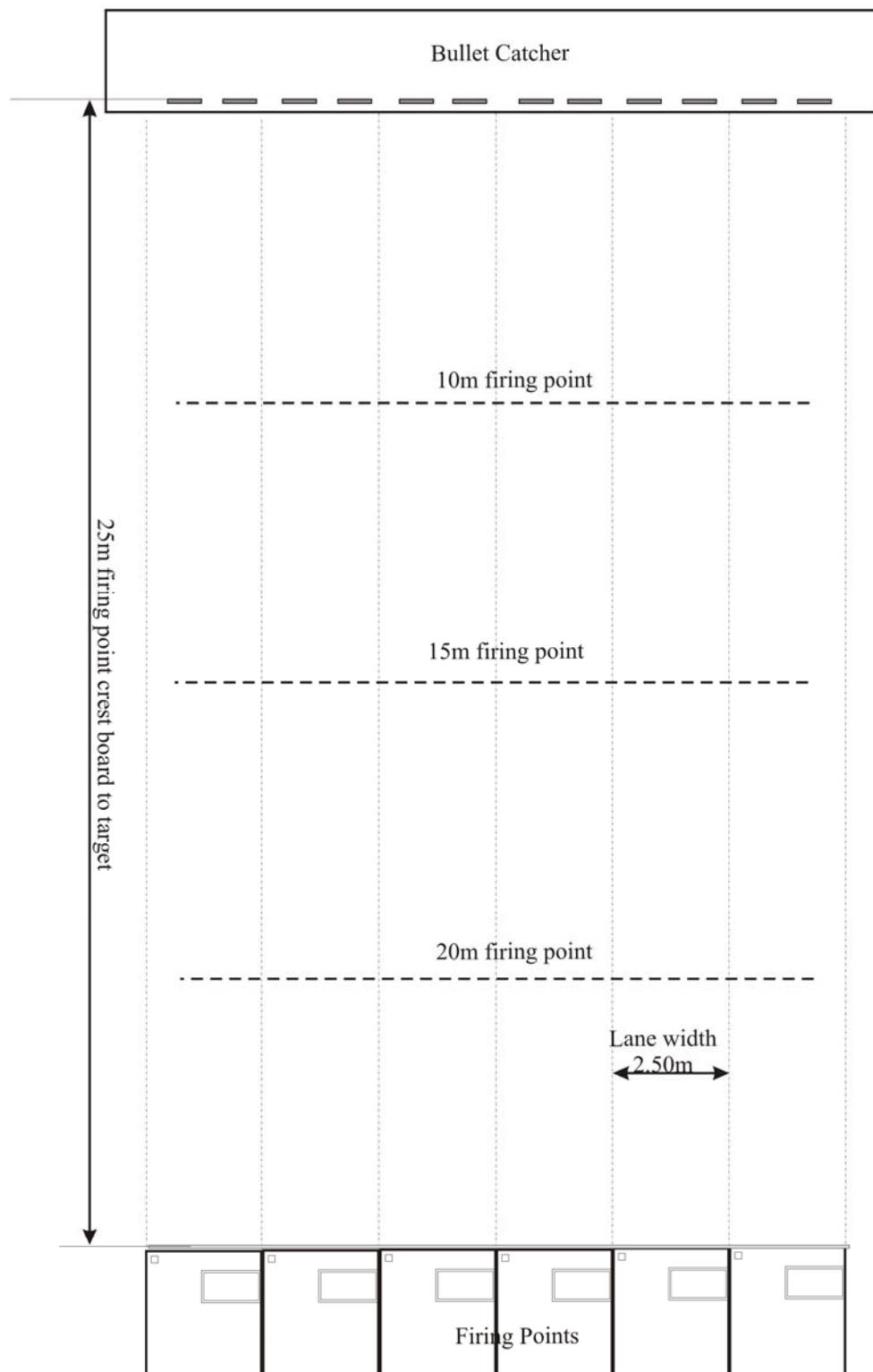

Figure 8-2 Range Floor Layout.

Reference Type Drawing 55702

Note: All dimensions are in millimetres,
are standard and may change
dependent upon the number of firing lanes.
Dimensions with (C) indicate
minimum dimensions for compliance

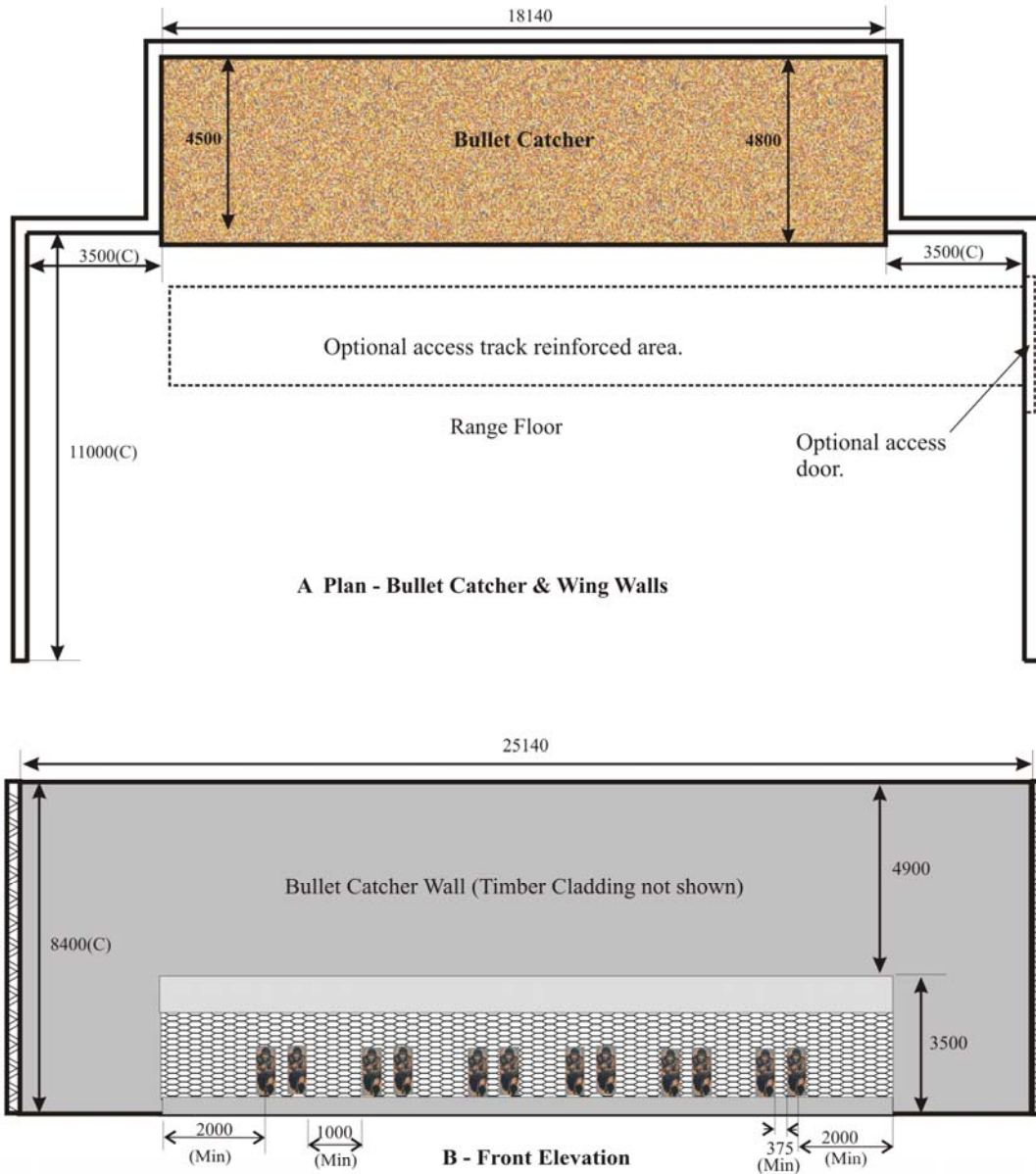

Figure 8-3 General Layout- Bullet Catcher

Reference Type Drawing 55702

All dimensions in millimetres except where indicated.
 Where dimensions are provided they are the minimum to ensure compliance with requirement. Other dimensions and details are determined from the design process.

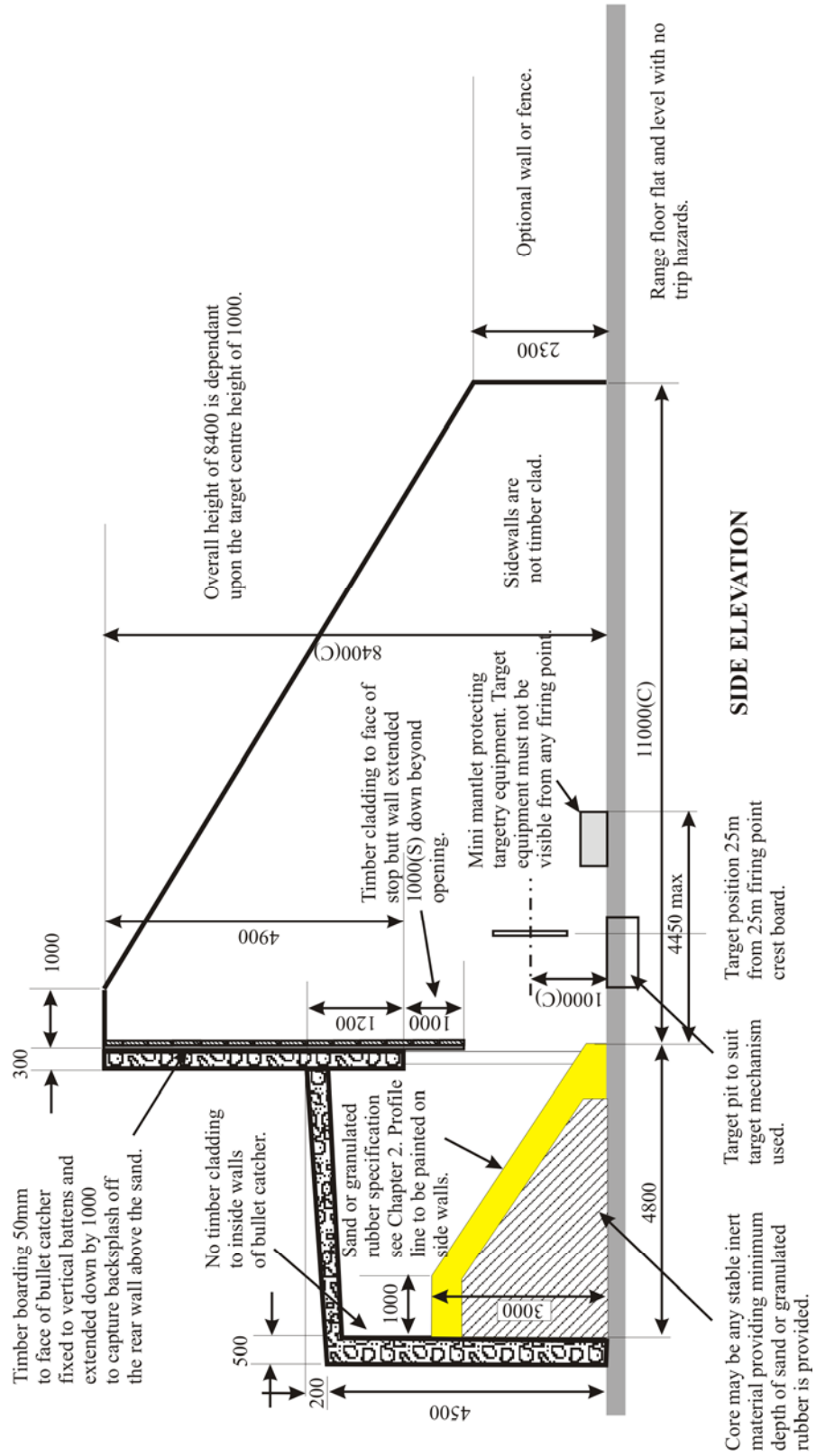

Figure 8-4 Detail at Bullet Catcher